



VIGOR PRECISION LTD.

力嘉精密有限公司

VS-1 SERVO

FOR REFERENCE

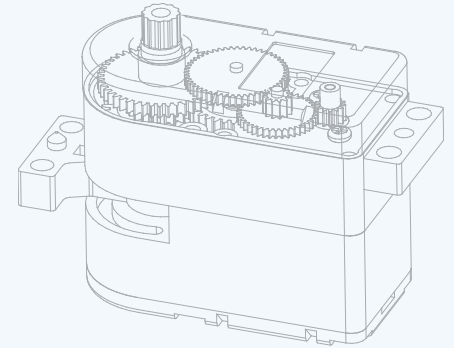

TECHNICAL DATA

Control System:	Pulse width control, 1500µs neutral	
Operating Voltage:	4.8V~6.0V (DC)	
STD Direction:	<u>Clockwise/pulse traveling</u> 800 to 2200 µsec.	
Test Voltage:	at 4.8V	at 6.0V
Operating Speed:	0.23sec/60° at no load	0.18sec/60° at no load
Stall Torque:	≥3.6kgf.cm(49.99 oz/in)	≥4.0kgf.cm(55.55 oz/in)
Running Current:	~0.25A	~0.35A
Stall Current:	~1.0A	~1.2A
Output Angle:	≥120°	
Dead Band Width:	5µsec	

FEATURES

Motor Type:	3 pole metal brush motor (Normal Motor)
Potentiometer Life:	100,000 cycles
Bearing:	Resin bush
Gear Material:	Resin
Spline Horns:	Spline type for VIGOR style
Connector Wire Length:	250mm(9.84in), 26AWG(Connector for FUTABA or JR style)
Special Features:	Design for Robot

DIMENSIONS

Size :	40.5×20.2×33.7mm (1.59×0.8×1.33in)
Weight:	34g (1.2 oz)

CASE AND HORN DRAWING

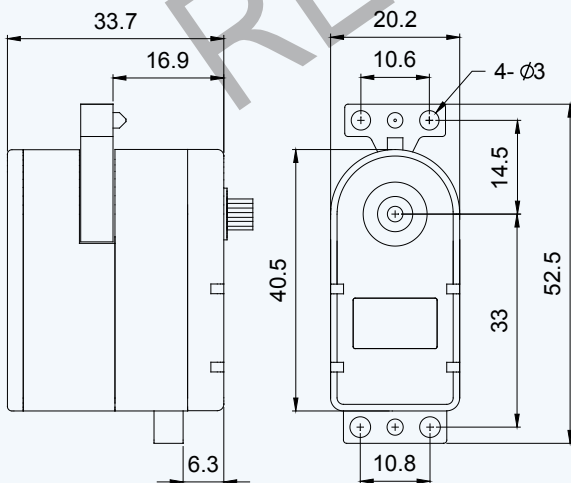

STD ACCESSORIES: Horn Screw × 1pc

- Double side Horn "E" × 1pc
- Frame Horn "H" × 1pc
- Frame Horn "V" × 1pc



Double side Horn "E"

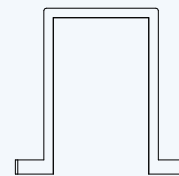

Frame Horn "H"



Frame Horn "V"

OPTION ACCESSORIES:

REMARKS:

