



VIGOR PRECISION LTD.

力嘉精密有限公司

VS-5M SERVO

FOR REFERENCE

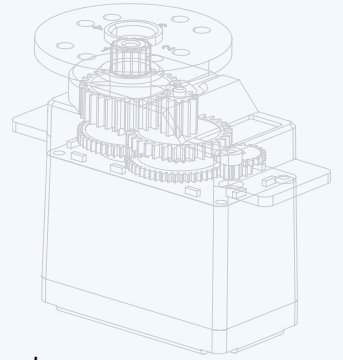

TECHNICAL DATA

Control System:	Pulse width control, 1500µs neutral	
Operating Voltage:	4.8V~6.0V (DC)	
STD Direction:	Counter clockwise/pulse traveling 800 to 2200 µsec.	
Test Voltage:	at 4.8V	at 6.0V
Operating Speed:	0.19sec/60° at no load	0.17sec/60° at no load
Stall Torque:	≥1.0kgf.cm(13.89 oz/in)	≥1.2kgf.cm(16.66 oz/in)
Running Current:	~0.25A	~0.3A
Stall Current:	~0.6A	~0.7A
Output Angle:	≥170°	
Dead Band Width:	5µsec	

FEATURES

Motor Type:	Coreless Motor
Potentiometer Life:	1,000,000 cycles
Bearing:	None
Gear Material:	Metal
Spline Horns:	Spline type for HITEC style
Connector Wire Length:	250mm(9.84in),28AWG(Connector for FUTABA or JR style)

DIMENSIONS

Size :	22.94×12.2×24.2mm(0.90×0.48×0.95in)
Weight:	11.5g(0.4 oz)

CASE AND HORN DRAWING

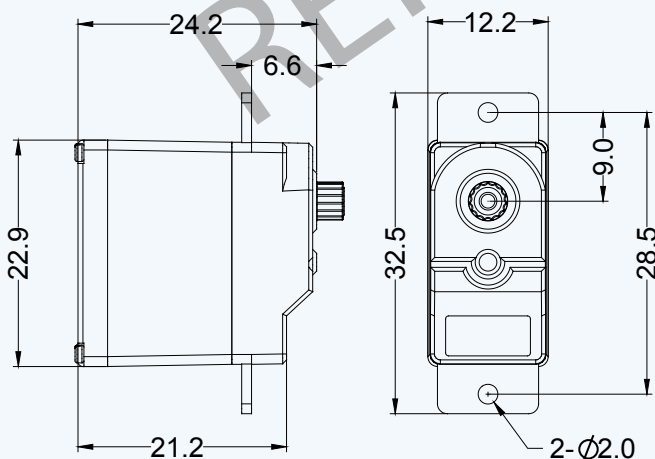

- STD ACCESSORIES:** Horn Screw × 1pc
 Cross Horn "C" × 1pc
 Circular Horn "C" × 1pc
 Single side Horn "C" × 1pc

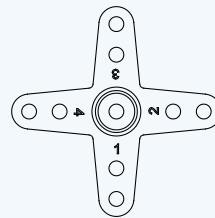

Cross Horn "C"

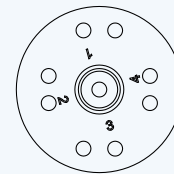

Circular Horn "C"



Single side Horn "C"

OPTION ACCESSORIES:

REMARKS:

